

# Square Tapered Steel Poles

NEC/CEC:  
Rated for Ordinary (Unclassified) Locations

## Applications

- To mount single or multiple luminaires to heights from 6.1 to 11.9 m (20 to 39 ft).

## Features

- 0.61 mm (2 in) pipe size tenon accepts a single luminaire or 2, 3, or 4 luminaires with appropriate pole-top mounting bracket.
- High strength shafts have a uniform taper and are made from 11 gauge commercial quality hot rolled steel.
- Base plates are of structural quality hot rolled steel with minimum yield strength of 36,000 psi.
- A 6.2 x 127.0 mm (3 in x 5 in) or 101.6 x 152.4 mm (4 in x 6 in) reinforced handhole with cover and grounding lug 355.6 mm (14 in) above the pole base is standard.
- Anchor bolts are furnished complete with nuts and washers, and are of 55,000 psi steel.

## Standard Materials/Finishes

- Lighting poles are steel with bronze powder coat finish (to match Appleton fixtures) or galvanized finish

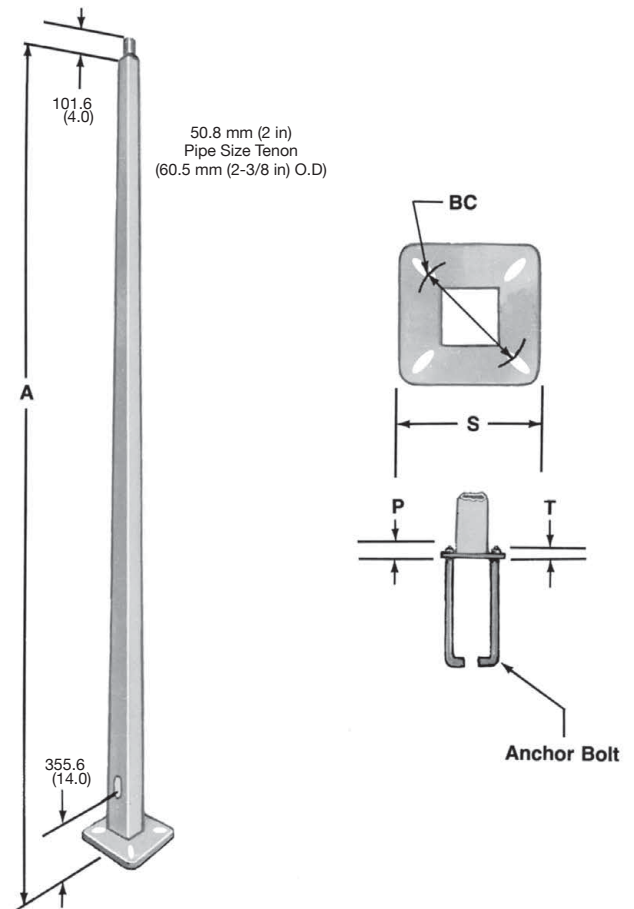

Mounting Height m (ft) A	Average Pole Weight kg (lb)	Pole Shaft Size mm (in)		Base Plate mm (in)			Anchorage: Anchor Bolt Dia. X Length mm (in)	Catalog Number	
		Bottom S	Top	Base Size (Square)	Bolt Circle	Base Thickness		Bronze	Galvanized
6.1 (20)	70 (155)	133 (5.25)	83 (3.25)	279.4 (11)	254.0 (10)	25.4 (1.0)	25x1016 (1x40)	G-PSTH-20	G-PSTH-20-GAL
7.6 (25)	93 (205)	159 (6.25)	95 (3.75)	304.8 (12)	317.5 (12.5)	25.4 (1.0)	25x1016 (1x40)	G-PSTH-25	G-PSTH-25-GAL
9.1 (30)	118 (260)	159 (6.25)	83 (3.25)	304.8 (12)	317.5 (12.5)	25.4 (1.0)	25x1016 (1x40)	G-PSTH-30	G-PSTH-30-GAL
10.7 (35)	138 (305)	169 (6.65)	83 (3.25)	330.2 (13)	317.5 (12.5)	25.4 (1.0)	25x1016 (1x40)	G-PSTH-35	G-PSTH-35-GAL
11.9 (39)	156 (345)	182 (7.15)	57 (2.25)	330.2 (13)	317.5 (12.5)	25.4 (1.0)	25x1016 (1x40)	G-PSTH-39	G-PSTH-39-GAL

① Dimensions may vary—Consult your local sales representative for specifications.

② Anchor bolts and templates are preshipped ahead of lighting poles.